



Austrian Institute of Construction Engineering
 Schenkenstrasse 4 | T+43 1 533 65 50
 1010 Vienna | Austria | F+43 1 533 64 23
 www.oib.or.at | mail@oib.or.at



European Technical Assessment

ETA-22/0785
of 20.12.2023

General part

Technical Assessment Body issuing the European Technical Assessment

Österreichisches Institut für Bautechnik (OIB)
Austrian Institute of Construction Engineering

Trade name of the construction product

Expansion joint Type F

Product family to which the construction product belongs

Cantilever expansion joints for road bridges

Manufacturer

Schreiber Brücken- Dehntechnik GmbH
Am Moosbach 10 + 12
74535 Mainhardt
Germany

Manufacturing plant

Schreiber Brücken- Dehntechnik GmbH
Am Moosbach 10 + 12
74535 Mainhardt
Germany

This European Technical Assessment contains

28 pages including 13 annexes
which form an integral part of this assessment.

This European Technical Assessment is issued in accordance with Regulation (EU) No 305/2011, on the basis of

European Assessment Document (EAD)
120111-00-0107 "Cantilever expansion joints for road bridges".

This European Technical Assessment replaces

European Technical Assessment ETA-22/0785,
of 16.12.2022.

Translations of this European Technical Assessment in other languages shall fully correspond to the original issued document and should be identified as such.

Communication of this European Technical Assessment, including transmission by electronic means, shall be in full. However, partial reproduction can be made with the written consent of the Österreichisches Institut für Bautechnik. Any partial reproduction has to be identified as such.

electronic copy
electronic copy
electronic copy
electronic copy
electronic copy
electronic copy
electronic copy

Specific parts

1 Technical description of the product

The cantilever expansion joint **Expansion joint Type F** is a kit consisting of the following components:

- Finger plates (Position 1 in Figure 1 and Figure 2) with different geometries to accommodate the range of movement capacity covered by this European Technical Assessment (ETA). Details are given in Clause 1.1 and Annex 1 to Annex 10.
- Anchorage consisting of anchor rods, hexagon nuts and washers (Position 2 in Figure 1), anchor disks and anchor plate (Position 4 in Figure 1) with different geometries. Details are given in Clause 1.2, Clause 1.3 and Annex 1 to Annex 10.
- Substructure of at least steel grade S235 J2+N according to EN 10025-2 (Position 3 in Figure 1) with a thickness of 25 mm. Details are given in Annex 1 to Annex 10.
- Sub-surface drainage system made of stainless steel, drip sheet made of EPDM and components for its fixation (Position 5 in Figure 1 and Figure 3) as detailed in Clause 1.4.
- Optional cover plate for footpath (Position 10 in Figure 2), related substructure and anchorage for the footpath area. The cover plate for footpath is held in vertical position by a spring made of elastomer, whereas the spring is covered by a spring box and, therefore protected from the environment. Details are given in Clause 1.5 and Annex 1 to Annex 10.
- Optional replaceable steel plate forming the kerb (Position 11 in Figure 2). Details are given in Clause 1.5.

The technical details of the components of the cantilever expansion joint kit are deposited with the Technical Assessment Body Österreichisches Institut für Bautechnik.

The subject of this ETA is the complete cantilever expansion joint kit **Expansion joint Type F**.

The adjacent pavement (Position 7 in Figure 1), the bridge deck/abutment (Position 8 in Figure 1) and the snowplough impact protection (Position 6 in Figure 1) are not part of the kit.

A schematic representation of the cantilever expansion joint **Expansion joint Type F** is shown in Figure 1 and detailed drawings are depicted in Annex 1 to Annex 10.

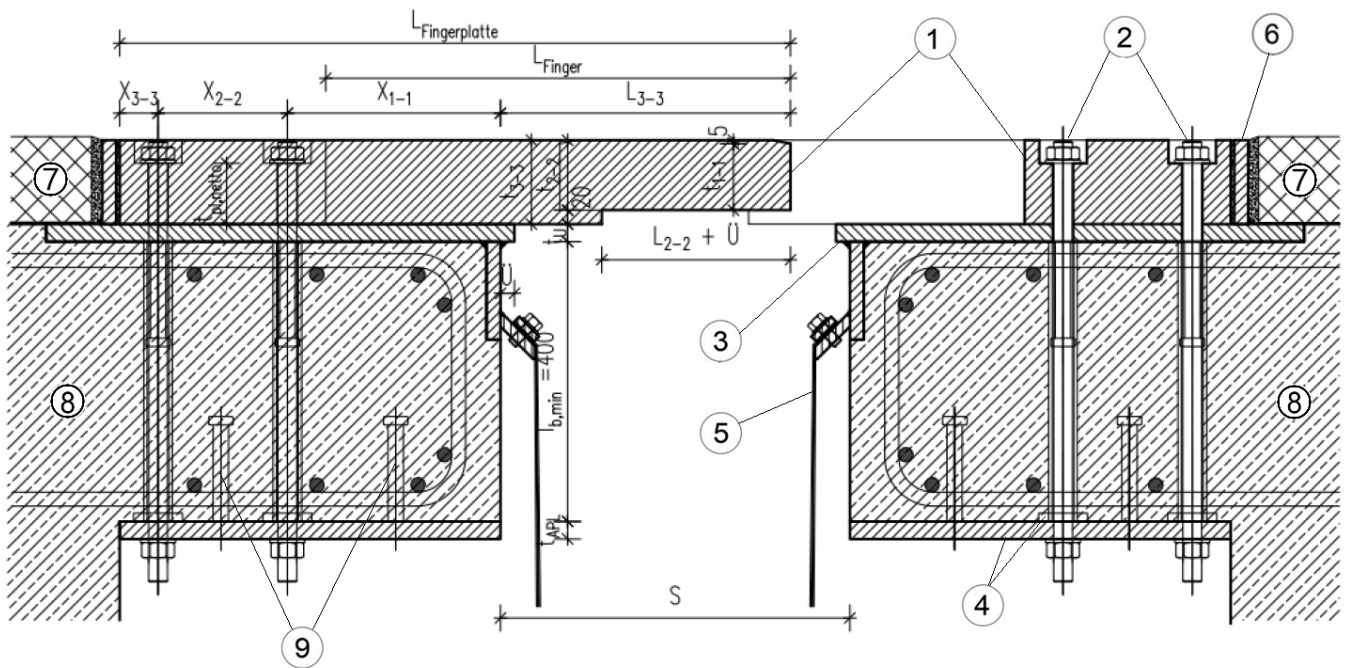

Figure 1: Exemplary cross section of the cantilever expansion joint
Expansion joint Type F

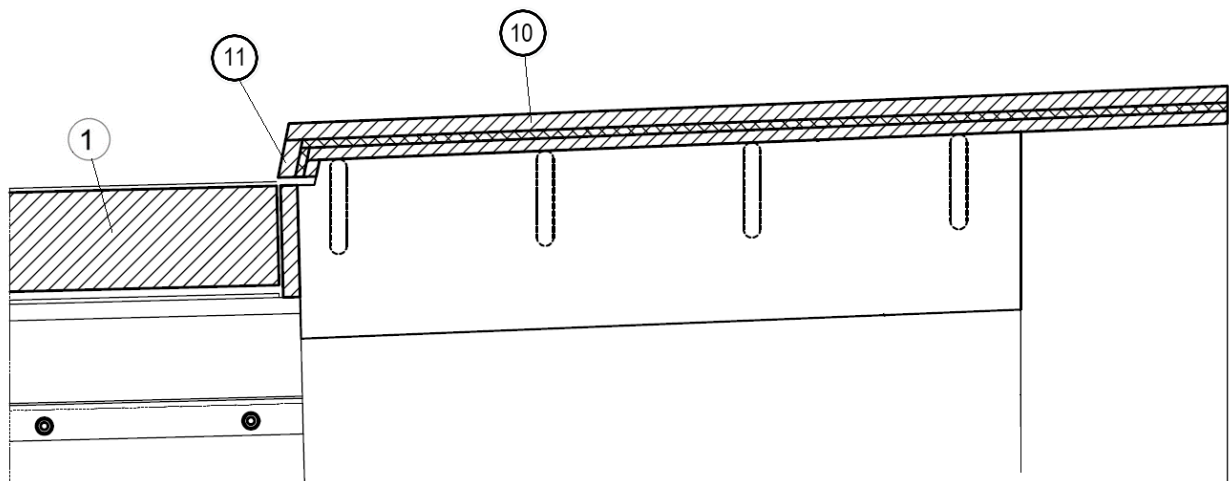

Figure 2: Schematic drawing of the footpath area of the cantilever expansion joint
Expansion joint Type F

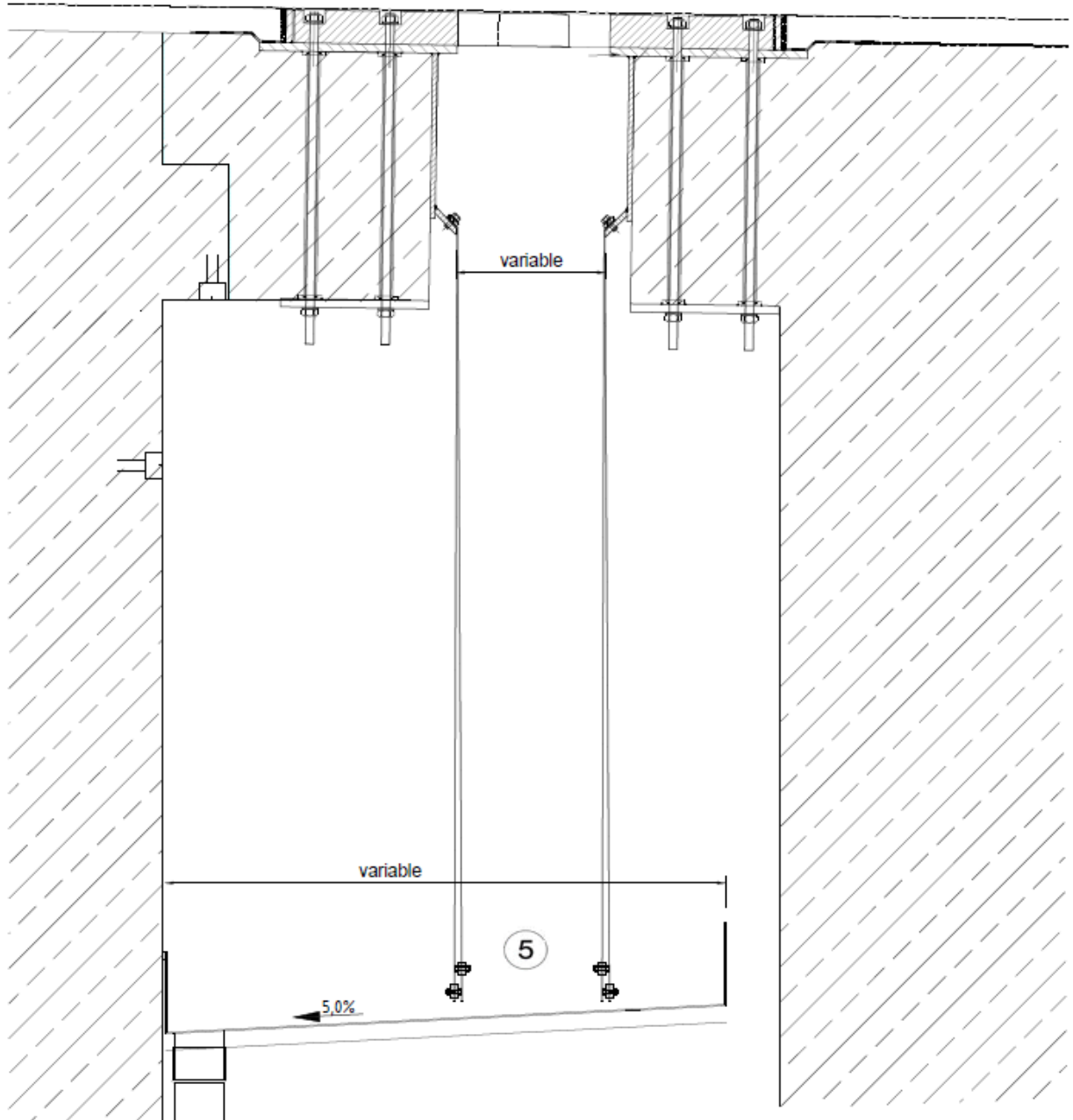

Figure 3: Schematic drawing of the sub-surface drainage system of the cantilever expansion joint
Expansion joint Type F

Key for Figure 1, Figure 2 and Figure 3:

- Pos.1 Finger plate
- Pos.2 Anchorage
- Pos.3 Substructure
- Pos.4 Anchor disks and anchor plate
- Pos.5 Sub-surface drainage system
- Pos.6 Snowplough impact protection (not part of the kit)
- Pos.7 Adjacent pavement (not part of the kit)
- Pos.8 Bridge deck/abutment (not part of the kit)
- Pos.9 Stud bolts
- Pos.10 Cover plate for footpath (optional)
- Pos.11 Kerb element (optional)

The stud bolts (Position 9 in Figure 1) mounted to the substructure (3) and the anchor plate (4) are for installation purposes only. They are not contributing to the mechanical resistance of the product.

The cantilevering concrete part (console) including the reinforcement, connecting the expansion joint to the bridge deck/abutment, shown in Figure 1 above, is not part of the kit covered by this ETA. Nevertheless, it is contributing to the performance of the kit. The minimum thickness of the console is 400 mm ($l_{b,min}$) and the minimum concrete quality is C40/50 low shrinkage concrete according to EN 206. The anchor forces according to Annex 12 shall be considered for the dimensioning of the reinforcement for connecting the expansion joint to the bridge deck/abutment (not part of the kit).

Provisions for proper installation (installation manual) of the **Expansion joint Type F** are provided for each delivered kit.

1.1 Finger plates (1)

Details of the finger plates (Position 1 in Figure 1 and Figure 2) of the different types of **Expansion joint Type F** are given in Table 1.

Table 1: Finger plates, dimensions (according to Figure 1) and materials

Type	Width in traffic direction	Length in direction of joint axis	Thickness	Material
	$L_{\text{Fingerplatte}}$ [mm] ¹⁾	[mm]	t_{3-3} [mm] ¹⁾	EN 10025-2
F 225	513	996	50	S355J2
F 285	618		60	S355J2
F 345	693		70	S355J2
F 400	748		80	S355J2
F 450	798		90	S355J2
F 520	868		100	S355NL
F 590	978		110	S355NL
F 650	1038		120	S355NL
F 715	1103		130	S355NL
F 785	1173		140	S355NL

¹⁾ See Figure 1

For corrosion protection Table 5 applies.

1.2 Anchorage (2)

The anchorage (Position 2 in Figure 1) is consisting of anchor rods with material quality 10.9, hexagonal nuts and washers with dimensions according to Table 2.

Table 2: Dimensions of the anchorage

Type	F 225	F 285	F 345	F 400	F 450	F 520	F 590	F 650	F 715	F 785
Diameter	M24	M27	M30	M30	M30	M30	M36	M36	M36	M36

For corrosion protection Table 5 applies.

1.3 Anchor discs and anchor plate (4)

The anchor plate and anchor discs (Position 4 in Figure 1) are made of at least steel grade S235J2 according to EN 10025-2 and the dimension are given in Table 3.

Table 3: Anchor discs and anchor plate, dimensions (according to Figure 1)

Type	F 225	F 285	F 345	F 400	F 450	F 520	F 590	F 650	F 715	F 785
Thickness anchor plate $t_{APL}^{1)}$ [mm]	20	20	25	25	25	25	25	25	25	25
Thickness anchor disk [mm]	12	12	12	12	12	12	12	12	12	12
Diameter anchor disk [mm]	70	70	70	70	70	70	70	70	70	70

¹⁾ See Figure 1

For corrosion protection Table 5 applies.

1.4 Sub-surface drainage system (5)

The sub-surface drainage system (Position 5 in Figure 1 and Figure 3) consists of a gutter made of stainless steel 1.4571 according to EN 10088-1, fixed to one side of the substructure and a drip sheet made of EPDM. For the fixation of the drip sheet, M12 screws made of stainless steel A4, washers made of stainless steel A4 and a clamping strip made of stainless steel 1.4571 according to EN 10088-1 is used.

1.5 Cover plate for footpath (10) and kerb (11)

The cover plate for footpath (Position 10 in Figure 2) and replaceable steel plate forming the kerb (Position 11 in Figure 2) are made of steel grade S 355 according to EN 10025-2 or stainless steel of grade 1.4571 according to EN 10088-1. The minimum thickness of the cover plate for footpath and the replaceable steel plate forming the kerb for the different types of **Expansion joint Type F** depends on the applied load model and material used.

The minimum thickness of the cover plate for footpath assessed for loads on footways according to EAD 120109-00-0107, Annex D, Clause D.2.3.1.3 and accidental loads on footways according to EAD 120109-00-0107, Annex D, Clause D.2.3.1.4 respectively is given in Table 4.

The minimum thickness of the replaceable steel plate forming the kerb assessed according to EAD 120109-00-0107, Annex D, Clause D.2.3.2.3.2 is also given in Table 4.

Table 4: Minimum thickness [mm] of the cover plate for footpath and the replaceable steel plate forming the kerb

Type	F 225	F 285	F 345	F 400	F 450	F 520	F 590	F 650	F 715	F 785
1.4571	15	20	20	20	20	20	20	20	20	20
S355	15	15	15	15	15	15	15	15	15	20

For corrosion protection Table 5 applies.

2 Specification of the intended use(s) in accordance with the applicable European Assessment Document (hereinafter EAD)

The cantilever expansion joint **Expansion joint Type F** is to be used in road bridges. The expansion joint kit is designated to be applied in new structures as well as for refurbishment of structures.

The use in moveable bridges (e.g. flap bridges, swing bridges) is not covered by this ETA.

The essential characteristics of the cantilever expansion joint **Expansion joint Type F** are assessed for operating temperature of -40°C up to $+45^{\circ}\text{C}$. The operating temperature is defined as the shade air temperature according to EN 1991-1-5, clause 1.5.2.

This has been assessed on basis of material characteristics (low temperature brittleness) of the elastomeric part of the sub-surface drainage device (drip sheet) and by consideration of the minimum operating temperature for the steel elements as detailed in Clause 3.1.1.

The cantilever expansion joint **Expansion joint Type F** is to be used for the user categories vehicle, cyclist and pedestrian as well as the actions categories standard action and optional action as detailed in Clause 3.1.1.

The provisions made in this European Technical Assessment are based on a working life of the kit of 50 years (working life category 4 according to EAD 120111-00-0107, Clause 1.2.2), provided that the kit is subject to appropriate use and maintenance as specified by the manufacturer in the maintenance instructions which follow every delivered kit. The indications given on the working life cannot be interpreted as a guarantee given by the producer or the Technical Assessment Body, but are to be regarded only as a means for choosing the right product in relation to the expected economically reasonable working life of the works.

The use of the cantilever expansion joint **Expansion joint Type F** according to this ETA is covering a maximum slope in traffic direction as stated in Table 9.

The working life of the cantilever expansion joint kit is based on the assessment of resistance to fatigue according to the fatigue load model 1 (FLM1_{EJ}), meaning the fatigue life may be considered as unlimited.

For the replaceable component drip sheet (part of the sub-surface drainage system) made of EPDM, a shorter working life is indicated.

For corrosion protection, the indications given in Table 5 apply.

3 Performance of the product and references to the methods used for its assessment

3.1 Performance of the product

Table 5: Performance of the product in relation to the essential characteristics

Essential characteristics	Method of assessment	Performance
Basic requirement for construction works 1: Mechanical resistance and stability		
Mechanical resistance	EAD 120111-00-0107, Clause 2.1.1	Fulfilled. This applies for the product according to Clause 1 considering the conditions given in Clause 3.1.1.
Resistance to fatigue	EAD 120111-00-0107, Clause 2.2.2	Fulfilled. This applies for the product according to Clause 1 considering the conditions given in Clause 3.1.1.
Seismic behaviour	EAD 120111-00-0107, Clause 2.2.3	According to Clause 3.1.2.
Movement capacity	EAD 120111-00-0107, Clause 2.2.4	According to Clause 3.1.3.
Cleanability	EAD 120111-00-0107, Clause 2.2.5	The cantilever expansion joint is cleanable. The gutter is accessible for cleaning purposes.
Watertightness	EAD 120111-00-0107, Clause 2.2.6	Watertight See Clause 3.1.4.
Durability	EAD 120111-00-0107, Clause 2.2.7.1: Corrosion	<u>Corrosivity categories:</u> C4 or C5 according to EN ISO 9223. <u>Components made of steel:</u> Corrosion protection systems: Durability range “high” (h) and “very high” (vh) according to EN ISO 12944-1 Bolts, nuts, washers: Hot dip galvanized according to EN ISO 10684 <u>Stainless steel components:</u> CRC III according to EN 1993-1-4; A4 according to EN ISO 3506
	EAD 120111-00-0107, Clause 2.2.7.2: Chemicals	Drip sheet of the sub-surface draining device made of EPDM: Durable
	EAD 120111-00-0107, Clause 2.2.7.3.1: Resistance to ageing resulting from temperature	
	EAD 120111-00-0107, Clause 2.2.7.3.2: Resistance to ageing resulting from Ozone	
Basic requirement for construction works 3: Hygiene, health and environment		
Content, emission and/or release of dangerous substances	EAD 120111-00-0107, Clause 2.2.8	No performance assessed.

Essential characteristics	Method of assessment	Performance
Basic requirement for construction works 4: Safety and accessibility in use		
Ability to bridge gaps and levels in the running surface	EAD 120111-00-0107, Clause 2.2.9.1: Allowable surface gaps and voids	Declaration of allowable gaps in respect to the user categories and different joint types is given in Clause 3.1.5.
	EAD 120111-00-0107, Clause 2.2.9.2: Level differences in the running surface	Unloaded conditions: no level differences (including steps) greater than 3 mm are occurring. Loaded conditions: maximum deflection under SLS load: <5 mm for all types
Skid resistance	EAD 120111-00-0107, Clause 2.2.10	Carriageway: PTV value 56 Footpath (cover plate): PTV value: Stainless steel: 51 Steel with corrosion protection: 50
Drainage capacity	EAD 120111-00-0107, Clause 2.2.11	Maximum drainage capacity 23,7 l/sec

3.1.1 Mechanical resistance and resistance to fatigue

Action categories covered by static calculation:

For the design situation ultimate limit state (ULS), the fundamental combinations of actions and the combination of actions for fatigue limit state (FLS) are considered and assessed.

For the design situation serviceability limit state (SLS) the characteristic combinations of actions and frequent combinations are considered and assessed.

Regarding optional actions, the accidental effects of a heavy wheel on the footpath, wheel shock on the upstand and the seismic design situations are considered and assessed.

Suitability of the components made of steel (see Clause 1.1) for low temperature (-40 °C) is assessed according to EN 1993-1-10, table 2.1.

Assessment of mechanical resistance and resistance to fatigue is based on the following conditions:

The skew angle between the traffic direction and the longitudinal axis of the joint $\beta = 90^\circ$ has been considered in the assessment.

For the load distribution the load distribution model A according to EAD 120111-00-0107, Clause 2.2.1 has been considered in the assessment.

Table 6: Preconditions for the assessment of mechanical resistance and resistance to fatigue

Partial safety factor γ_{M0} (EN 1993-2)	1.00
Partial safety factor γ_{M2} (EN 1993-2)	1.25
Partial safety factor γ_{M3} (EN 1993-2)	1.25
Partial safety factor γ_{Mf} (EN 1993-2)	1.15
Partial safety factor γ_{Ff} (EN 1993-2)	1.00
Fatigue load model (EAD 120109-00-0107, D.2.3.3.2)	FLM 1 _{EJ}
Additional dynamic amplification factor $\Delta\phi_{fat}$ (EAD 120111-00-0107)	1.3
Vertical upswing U_v (EAD 120111-00-0107)	0.3
Horizontal upswing U_h (EAD 120111-00-0107)	0.0
Combination factor ψ_{OT} (EAD 120109-00-0107, D.2.4.2.1)	1.00
Combination factor ψ_{Od} (EAD 120109-00-0107, D.2.4.2.1)	1.00
Combination factor ψ_{Ok} (EAD 120109-00-0107, D.2.4.2.1)	0.50
Combination factor ψ_{Ok} (EAD 120109-00-0107, D.2.4.2.1)	0.50

Outcome of the assessment of mechanical resistance:

At ULS load level and under imposed displacements, there is no contact between intersecting cantilevers.

At SLS load level the following has been assessed:

- No yielding of any part of the joint;
- Vertical deflections under loaded conditions are smaller than 5 mm;
- No contact between intersecting cantilevers;
- No separation of contact surfaces occurs.

The assessed anchor forces are given in Annex 12.

Outcome of the assessment of resistance to fatigue:

No fatigue failure during the intended working life of 50 years. This has been assessed considering a slope in traffic direction of 6 %.

Note: Regarding restrictions to the maximum slope in traffic direction related to movement capacity see Table 9.

The assessed anchor forces are given in Annex 12.

3.1.2 Seismic behaviour

The assessed approaches and related maximum gaps during an earthquake are given in Table 7. Whereas, “gap” means “distance between the tooth ends of the opposing finger plates in opening position”, according to EAD 120111-00-0107, Clause 2.2.3.

Table 7: Seismic behaviour of **Expansion joint Type F** for skew angle $\beta = 90^\circ$

Approach according to EAD 120109-00-0107, Table D.8	Maximum gap during earthquake
Approach A1	As for the SLS condition (no “gap”)
Approach A2, B1, B2	160 mm
Approach B3	240 mm
Approach B4	After earthquake: max. gap 300 mm for emergency traffic

Note: Due to the geometry of the finger plates, the displacements during the earthquake in vertical and transversal direction shall not exceed the values given in Clause 3.1.3.

3.1.3 Movement capacity

Table 8: Movement capacity of **Expansion joint Type F** (for an angle of 90° between main movement direction of the bridge and joint axis) in longitudinal direction

Longitudinal movement range				
Type	Maximum longitudinal movement	Minimum opening	Minimum overlap *)	Minimum gap "S" in central position **)
	[mm]	[mm]	[mm]	[mm]
F 225	225	10	5	252,5
F 285	285			282,5
F 345	345			312,5
F 400	400			345
F 450	450			370
F 520	520			405
F 590	590			440
F 650	650			500
F 715	715			547,5
F 785	785			612,5

*) Overlap of the finger tips at maximum opening (according to EAD 120111-00-0107, Figure 4)

**) For definition of "S" see Figure 1.

The maximum transversal movement is ± 8 mm for all types of **Expansion joint Type F**.

The maximum vertical movement at minimum opening and in horizontal position (slope in traffic direction 0 %) is 20 mm for all types of **Expansion joint Type F**.

The influence of longitudinal slopes with respect to movement capacity is given in Table 9.

The minimum opening of 10 mm applies for the unloaded condition as well as loading to SLS and ULS level.

The minimum overlapping of 5 mm applies for the unloaded condition as well as loading to SLS level.

As there is no direct connection between the two sides of the joint there are no reaction forces resulting from the movement of the superstructure.

Table 9: Maximum longitudinal slopes for cantilever expansion joint **Expansion joint Type F** allowing the minimum opening position of 10 mm without collision of the finger plates on the opposite side for horizontal application of bridge bearings

Type	Maximum longitudinal slope
	[%]
F 225	6
F 285	6
F 345	6
F 400	6
F 450	6
F 520	5
F 590	5
F 650	4
F 715	4
F 785	3

Note: The values for the maximum longitudinal slope given in Table 9 for the different types of **Expansion joint Type F** are limited due to geometrical conditions. Resistance to fatigue is assessed for a longitudinal slope of 6% for all types of **Expansion joint Type F**. If appropriate measures are taken to prevent collision of the finger plates on the opposite side (e.g. bridge bearings applied with the same longitudinal slope as the bridge) this higher value are covered by the product according to this ETA.

3.1.4 Watertightness

Assessment of durability of the components of the sub-surface drainage device according to Table 5 and the assessment of drainage capacity of the gutter according to Table 5 demonstrates the watertightness of the product.

3.1.5 Allowable surface gaps and voids

Table 10: Standard geometry of cantilever expansion joint **Expansion joint Type F** in respect to its movement capacity

Type	Angle between traffic direction and joint axis	Maximum longitudinal movement for user category		
		Vehicles	Cyclists *)	Pedestrians
	β [°]	[mm]	[mm]	[mm]
F 225	90	225		
F 285		285		
F 345		345		
F 400		400		
F 450		450		
F 520		520		
F 590		590		
F 650		650		
F 715		715		
F 785		785		

*) For the user category cyclists with optional cover plate only.

4 Assessment and verification of constancy of performance (hereinafter AVCP) system applied, with reference to its legal base

According to the decision 2001/19/EC¹ of the European Commission, as amended, the system(s) of assessment and verification of constancy of performance (see Annex V of Regulation (EU) No 305/2011) is 1.

5 Technical details necessary for the implementation of the AVCP system, as provided for in the applicable EAD

Technical details necessary for the implementation of the AVCP system are laid down in in the control plan deposited by the Technical Assessment Body Österreichisches Institut für Bautechnik.

The notified product certification body shall visit the factory at least once a year for surveillance of the manufacturer.

Issued in Vienna on 20.12.2023
by Österreichisches Institut für Bautechnik

The original document is signed by:

Thomas Rockenschaub
Deputy Managing Director

¹ Official Journal of the European Communities N° L 005, 10.1.2001, p. 6-7

electronic copy

electronic copy electronic copy electronic copy electronic copy electronic copy electronic copy electronic copy electronic copy electronic copy electronic copy

SCHNITT MITTELSTELLUNG

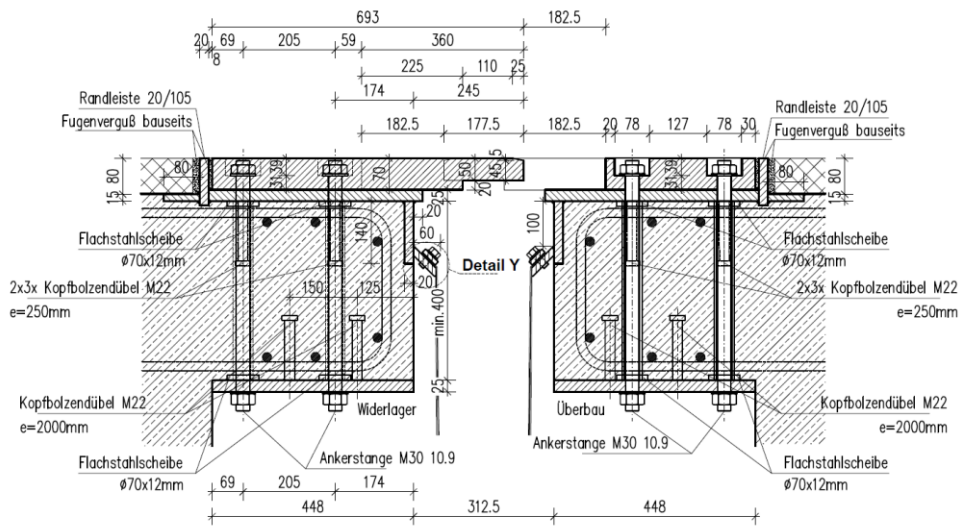

GRUNDRISS MITTELSTELLUNG

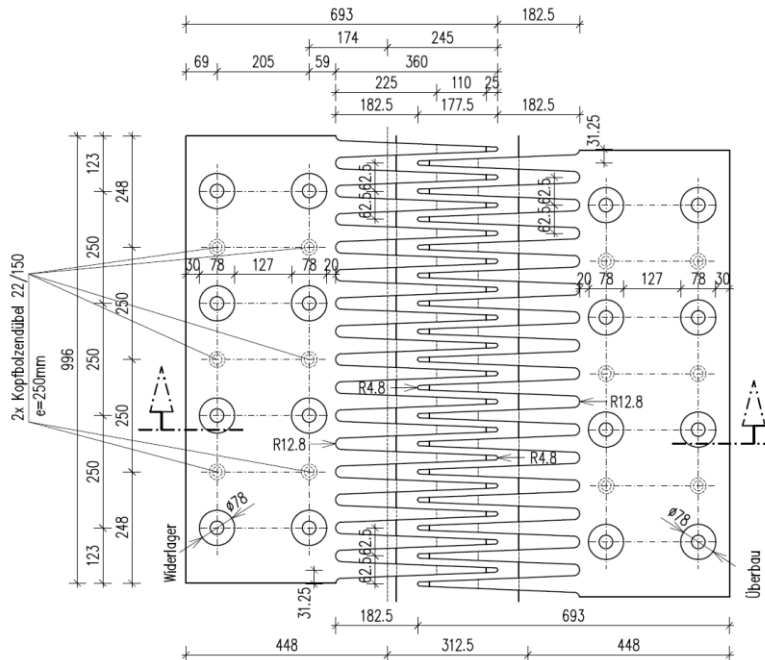

Querschnitt Gehweg Minimalstellung

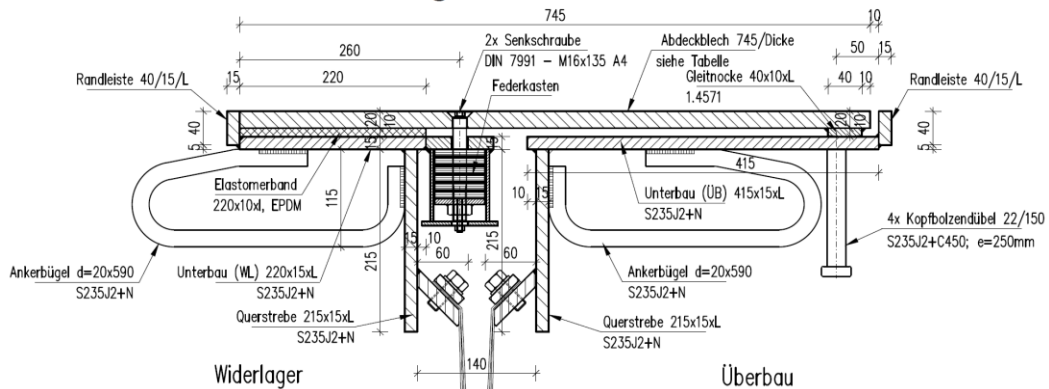

Translation is given in Annex 11.

Expansion joint Type F 345

Annex 3 of European Technical Assessment ETA-22/0785

electronic copy

SCHNITT MITTELSTELLUNG

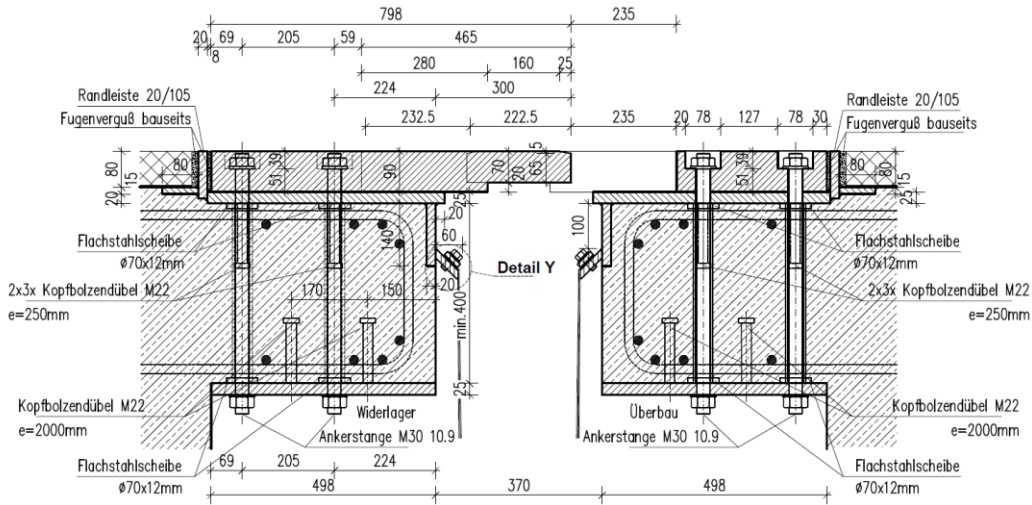

GRUNDRISS MITTELSTELLUNG

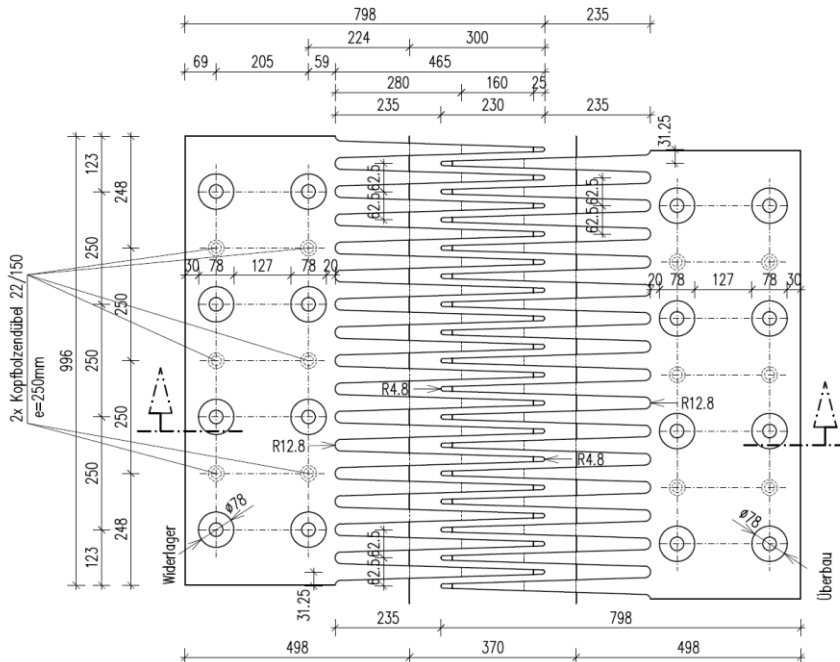

Querschnitt Gehweg Minimalstellung

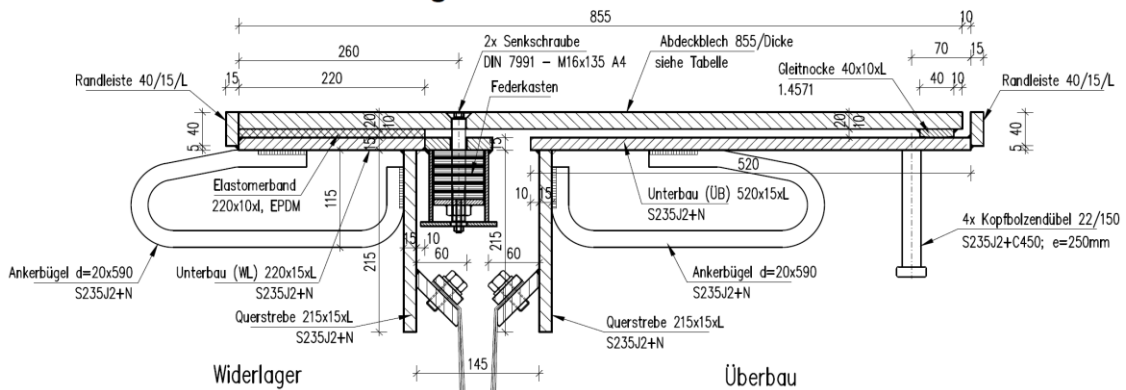

Translation is given in Annex 11.

Expansion joint Type F 450

Annex 5 of European Technical Assessment ETA-22/0785

electronic copy

SCHNITT MITTELSTELLUNG

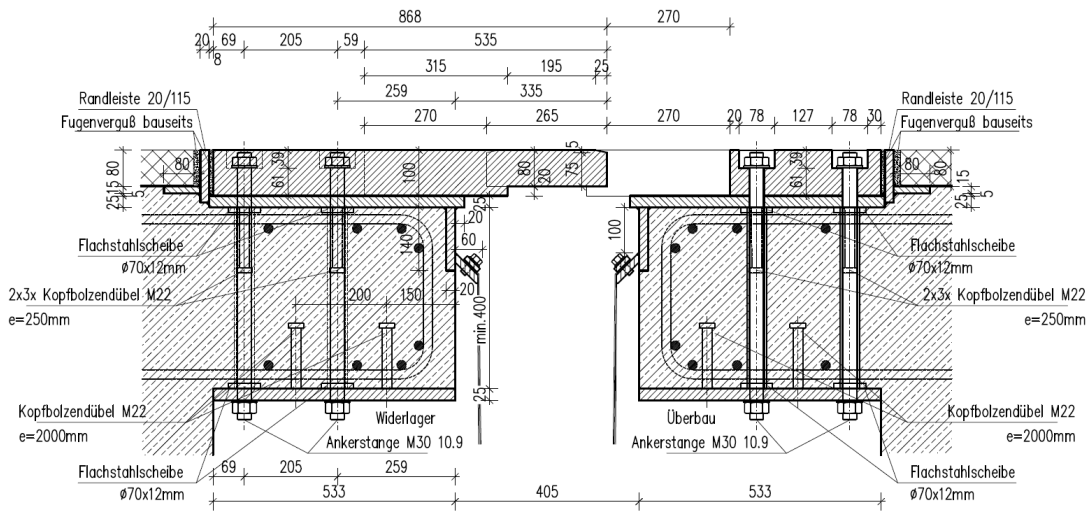

GRUNDRISS MITTELSTELLUNG

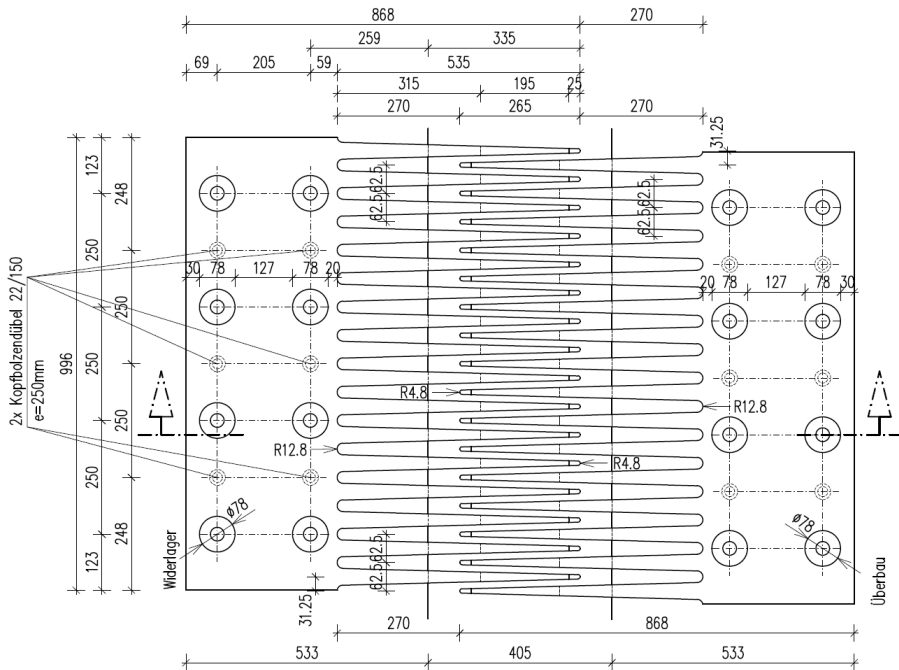

Querschnitt Gehweg Minimalstellung

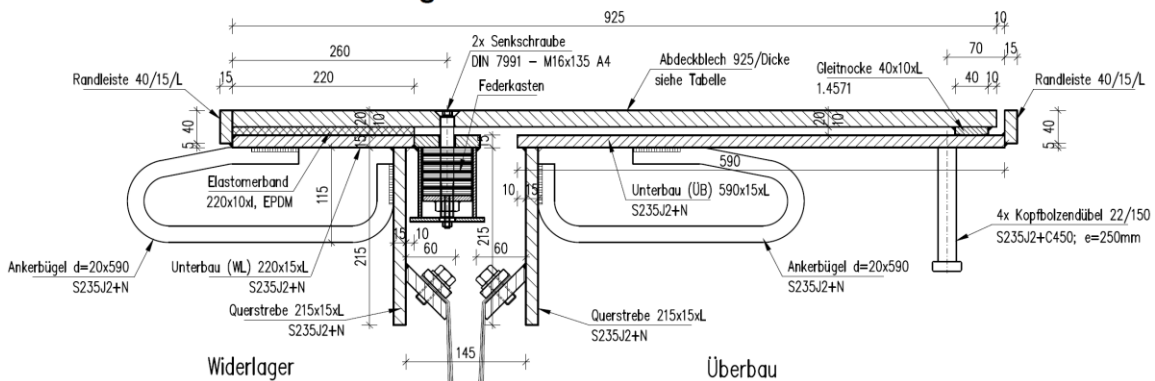

Translation is given in Annex 11.

Expansion joint Type F 520

Annex 6 of European Technical Assessment ETA-22/0785

electronic copy

SCHNITT MITTELSTELLUNG

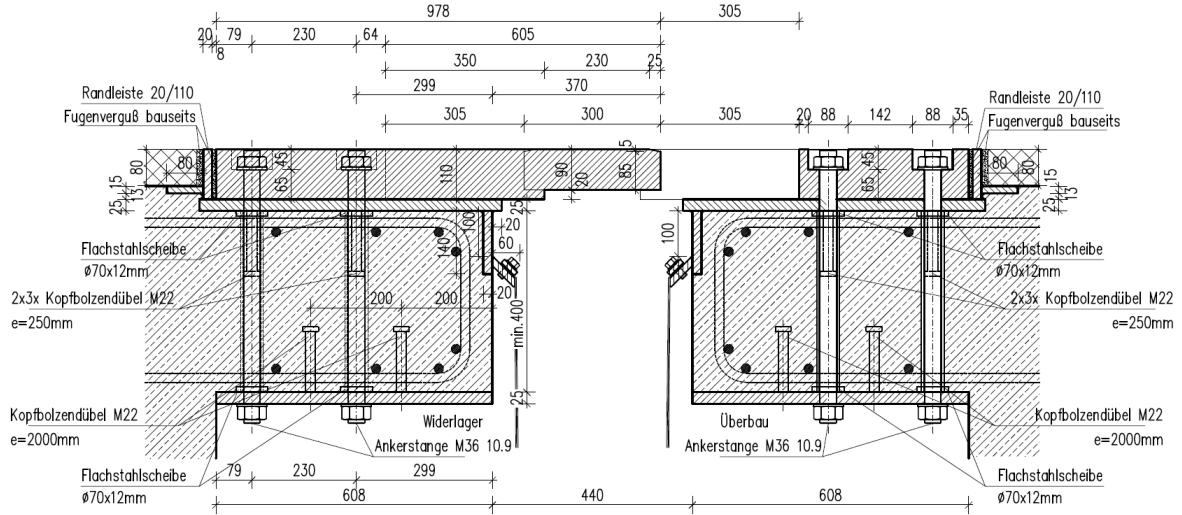

GRUNDRISS MITTELSTELLUNG

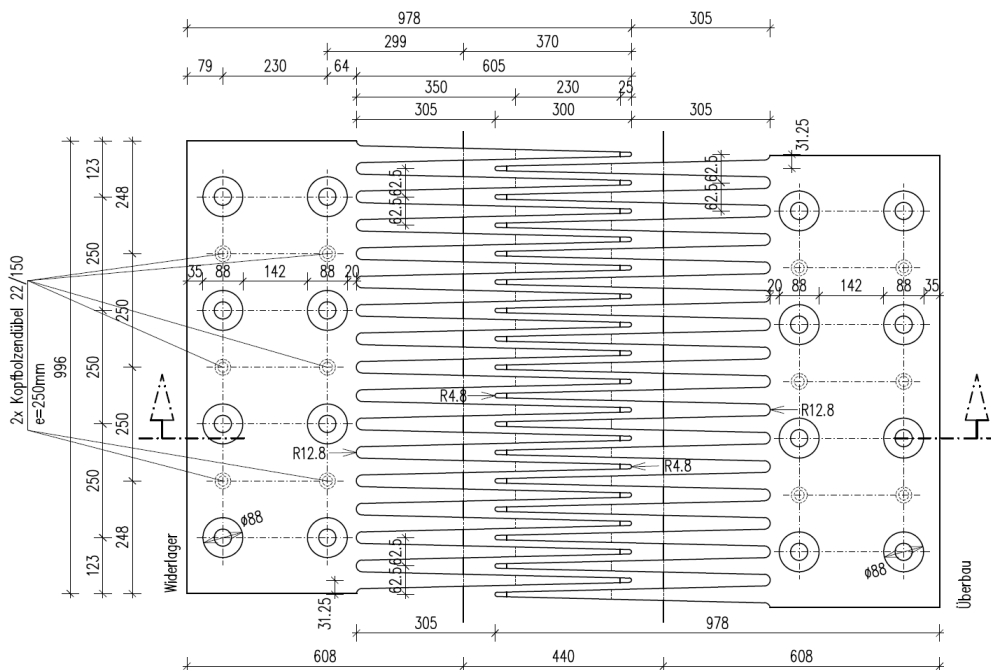

Querschnitt Gehweg Minimalstellung

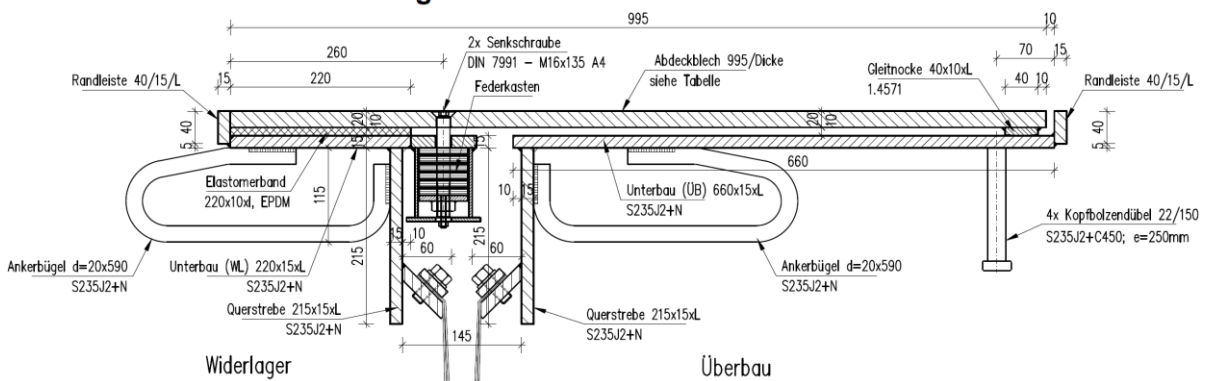

Translation is given in Annex 11.

Expansion joint Type F 590

Annex 7 of European Technical Assessment ETA-22/0785

electronic copy

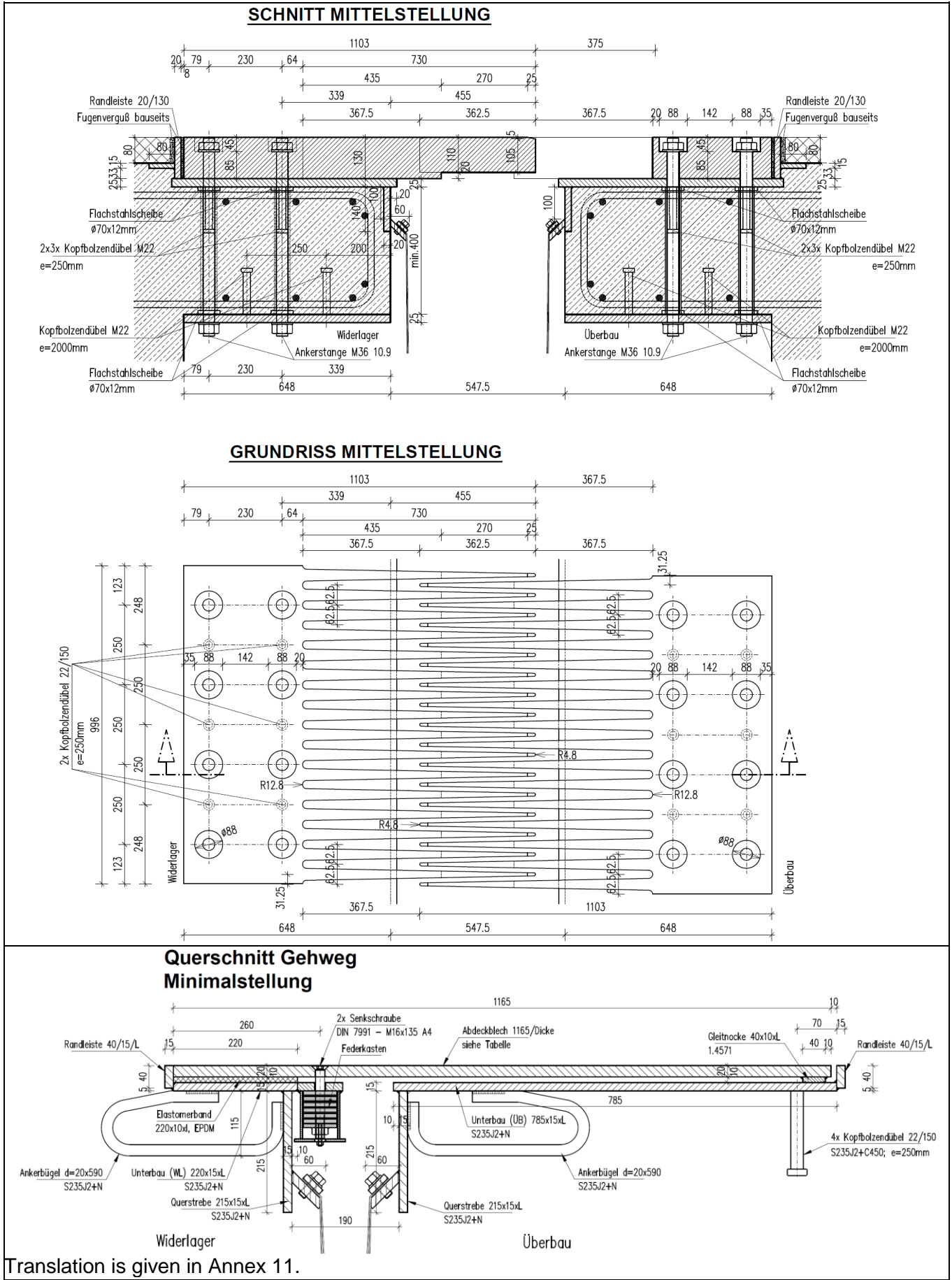

Translation is given in Annex 11.

Carriageway		Note
German	English	
SCHNITT MITTELSTELLUNG	Cross section central position	
Randleiste	Snowplough impact protection	not part of the kit
Fugenverguß bauseits	Joint sealing by client	not part of the kit
Flachstahlscheibe	Anchor disk	
Kopfbolzendübel	Shear stud	
Ankerstange	Anchor rod	
Widerlager	Abutment	not part of the kit
Überbau	Bridge deck	not part of the kit
GRUNDRISS MITTELSTELLUNG	Top view central position	
Footpath		
Querschnitt Gehweg Minimalstellung	Cross section footpath minimum opening	
Randleiste	Edge strip	
Ankerbügel	Anchor loop	
Elastomerband	Elastomeric strip	
Unterbau	Substructure	
Querstrebe	Cross strut	
Senkschraube	Countersunk screw	
Federkasten	Spring box	
Abdeckblech Dicke siehe Tabelle	Cover plate thickness see Table	See Table 4
Gleitnocke	Sliding strip	
Widerlager	Abutment	not part of the kit
Überbau	Bridge deck	not part of the kit
Expansion joint Type F – Translations for Annex 1 - 10		Annex 11 of European Technical Assessment ETA-22/0785

The specified forces and moments refer to the effective width of a tandem wheel of 60 cm.
 $e_{h,K} = 20 \text{ cm}$
 $e_{v,K} = 20 \text{ cm}$

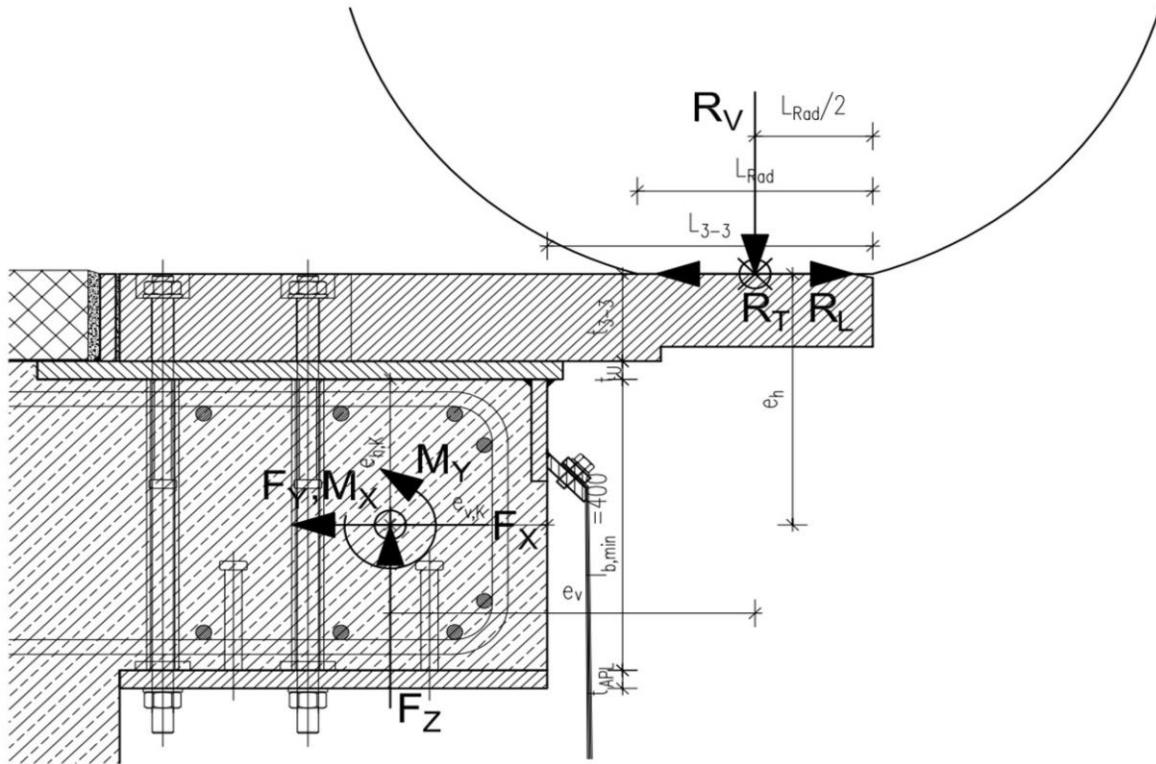

Type	e_h	e_v	Mechanical resistance - ULS				Resistance to fatigue		
	[cm]	[cm]	M_x [kNcm]	M_y [kNcm]	F_z [kN]	F_x [kN]	ΔM_y [kNcm]	ΔF_z [kN]	ΔF_x [kN]
F 225	27,5	23,5	475,9	5583,8	202,5	20,3	3977,8	136,5	56,0
			-475,9	3933,8	202,5	-20,3			
F 285	28,5	26,5	536,6	6221,3	202,5	20,3	4415,3	136,5	56,0
			-536,6	4511,3	202,5	-20,3			
F 345	29,5	29,5	597,4	6858,8	202,5	20,3	4852,8	136,5	56,0
			-597,4	5088,8	202,5	-20,3			
F 400	30,5	32,5	658,1	7496,3	202,5	20,3	5290,3	136,5	56,0
			-658,1	5666,3	202,5	-20,3			
F 450	31,5	35,0	708,8	8032,5	202,5	20,3	5659,5	136,5	56,0
			-708,8	6142,5	202,5	-20,3			
F 520	32,5	38,5	779,6	8771,3	202,5	20,3	6165,3	136,5	56,0
			-779,6	6821,3	202,5	-20,3			
F 590	33,5	42,0	850,5	9510,0	202,5	20,3	6671,0	136,5	56,0
			-850,5	7500,0	202,5	-20,3			
F 650	34,5	46,5	941,6	10451,3	202,5	20,3	7313,3	136,5	56,0
			-941,6	8381,3	202,5	-20,3			
F 715	35,5	50,5	1022,6	11291,3	202,5	20,3	7887,3	136,5	56,0
			-1022,6	9161,3	202,5	-20,3			
F 785	36,5	55,5	1123,9	12333,8	202,5	20,3	8597,8	136,5	56,0
			-1123,9	10143,8	202,5	-20,3			

**Expansion joint Type F
 Anchor forces**

**Annex 12 of European Technical
 Assessment ETA-22/0785**

